



AVANTALINE[®] WALL CLADDING

Technical Manual

SELECTION AND SPECIFICATION

AVANTALINE®

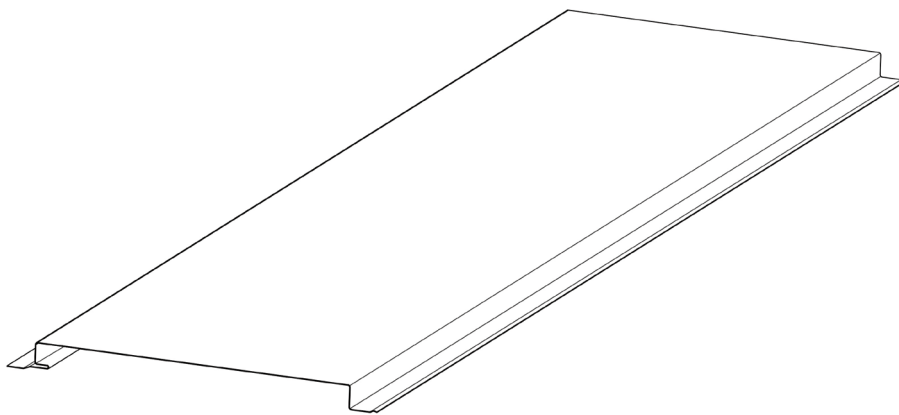

AVANTALINE® WALL CLADDING

FEATURES

- Visually striking
- Available in 25mm height
- All panels have a 15mm groove joint between them through which fasteners are installed
- Available in standard and matt COLORBOND® steel colours, as well as Unicote® Lux
- Manufactured from non-combustible materials
- Fully tested and NCC compliant with a full range of load performance data tables to suit most applications.
- Proudly Australian Made

APPLICATIONS

Part of Stramit's premier Architectural range, AvantaLine® cladding can be installed horizontally or vertically to suit the architectural requirements of the project.

A variety of finishes make AvantaLine® cladding an easy choice for architectural cladding.

AvantaLine® cladding is only intended for use in commercial/industrial/residential wall cladding applications. Do not use for any other purpose.

IMPORTANT NOTICE AND DISCLAIMER

The information contained within this brochure is for general use and information only. Before application in a particular situation, Stramit recommends that you obtain appropriate independent qualified expert advice confirming the suitability of product(s) and information in question for the application proposed. While Stramit accepts its legal obligations, be aware however that to the extent permitted by law, Stramit excludes all liability (including liability for negligence) for all loss and damage resulting from the use of the information provided in this brochure.

MATERIALS

Stramit's AvantaLine® cladding is manufactured from G300 colour coated steel, aluminium-zinc-magnesium or zinc-aluminium alloy coated steel. In some locations severe environment colour-coated steel may be available by arrangement.

Colour-coated steels are in accordance with AS/NZS 2728:2013 - Type 4 and, for the substrate, with AS 1397:2021. Aluminium-zinc-magnesium alloy coated AM100/AM125, zinc-aluminium alloy coated AZ150 conforms to AS 1397:2021.

Stramit has a comprehensive range of colours as standard. Ask your nearest Stramit location for colour availability.

STRAMIT AVANTALINE® CLADDING COLORBOND® XRW 0.55mm BMT – SHEETING MASS				
RIB HEIGHT (mm)	TOP WIDTH (mm)	COVER (mm)	GROOVE JOINT (mm)	MASS (kg/m ²)
25	285	300	15	5.93

ADVERSE CONDITIONS

AvantaLine® wall cladding will give excellent durability in almost all locations. It is however important to choose the correct coating for each application environment as shown in the table below. Durability recommendations do vary based on the application of the product, in walling installations. The table below shows the suitability of coating types for different exposure conditions.

Suitability of coating type for site exposure conditions	Wall cladding Distance from	
	breaking surf/ exposed marine	calm marine
COLORBOND® Classic/Matt	> 800m	> 200m
COLORBOND® Ultra	> 500m	> 100m
Unicote® Lux	Suitable for atmospheric classifications C1 - C3	

The suitability and exposure table above is current at the time of publication and is a guideline only; conditions will vary from site to site. Please check the BlueScope Technical Bulletins at www.bluescopesteel.com.au for the latest information and guidance on selection, maintenance and durability of ZINCALUME® and COLORBOND®, and unicote.com.au for information on Unicote® Lux. If uncertain about the appropriate coating for a particular application, or if the product is to be used in environments affected by industrial emissions, fossil fuel combustion, animal farming, or has unwashed areas, please contact your nearest Stramit office for advice.

COMPATIBILITY

All building products need to be checked for compatibility with adjacent materials. These checks need to be for both direct contact between materials, and where water runs from one material to another. The following guidelines generally avoid material incompatibility:

- For zinc-aluminium alloy coated steel, colour coated steel and galvanised steel roofs **avoid** copper, lead, green or treated timber, stainless steel, uncoated steel and mortar or concrete.

Note: refer to AS 1562.1:2018 or HB39 for more detail.

TESTING

Stramit has in-house, purpose built, air-box testing equipment used to design, develop and improve products for the Australian market. In addition, many Stramit® products are tested by independent organisations.

This ongoing research and development activity ensure that Stramit remains at the forefront of innovation, design and consumer information.

ARCHITECTURAL SPECIFICATION

This specification can be found on the Stramit website and can be easily downloaded onto your documentation.

The walling shall be 0.55mm BMT Stramit AvantaLine® cladding in continuous lengths with 25mm high ribs and flat tops spaced at specified centres to suit fixing methods.

Sheeting material shall be protected steel sheet to Australian Standard AS 1397, with a minimum yield stress of 300MPa (Grade G300) and an AM100/AZ150 coating with an oven-baked paint film of selected colour, or a plain AM125/AZ150 coating.

The sheeting shall be fixed to the girts/battens in accordance with the manufacturer's recommendations. Suitable fixing screws in accordance with Australian Standard AS 3566, suitable for minimum corrosivity category 3, shall be used at every support.

Sheets shall be laid in such a manner that the approved side lap faces away from the prevailing weather.

Flashings shall be supplied in compatible materials as specified; minimum cover of flashing shall be 150mm.

All sheeting shall be fixed in a workman-like manner, leaving the job clean and weathertight.

All debris (nuts, screws, cuttings, filings etc.) shall be cleaned off daily.

DESIGN

SPAN TABLES

Stramit tests to Australian Standard AS 1562.1:2018 called up in the National Construction Code to provide span load tables.

The spans shown below are based on the direct pressure testing method described in the current version of AS 1562.1:2018 and take account of wind resistance including local pressure zone effects.

Pressures are based on AS 4055:2021 or AS/NZS 1170.2:2021. Where the two standards differ, the worst case has been taken for each classification.

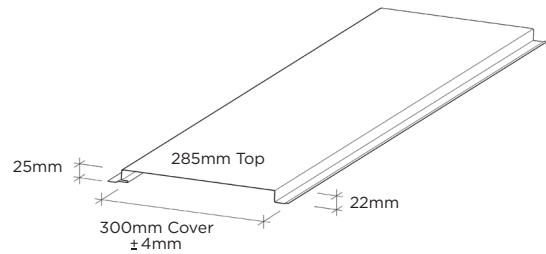

Data should only be used for buildings with dimension limits given in AS 4055:2021, 7m or less in average height, 16m max width and length less than 5 times the width, where both length and width exceed the building height and site is unaffected by land topography. Maximum roof pitch 35°. Refer to AS 4055:2021 for more detail. Designs for the most popular profiles are shown below.

STRAMIT AVANTALINE® CLADDING MAXIMUM SPAN CHART (mm)								
rib height (mm)	top width (mm)	cover (mm)	wall					overhang
			pressure (kPa)		double spans	equal spans	internal (end) span combination	(mm)
		service-ability	strength					
N1w or Region A (TC3, FS)								
25	285	300	0.55	0.94	1200	1200	1200 (950)	100
N2w or Region B1 (TC3, FS) or Region A (TC2.5,PS)								
25	285	300	0.80	1.30	1100	1150	1200 (950)	100
N3w or Region A (TC2, NS) or Region B1 (TC2.5, PS) or Region B2 (not WA) (TC3, FS)								
25	285	300	1.00	2.03	850	900	1000 (800)	100

The table above gives the maximum spans. Use of 450mm or 600mm spans will reduce the risk of any aesthetic issues. Internal spans must have both end spans 20% shorter. Values are only valid for use on steel supports 0.55mm G550 or thicker. Where thinner supports are used, fastener capacity must be checked. For 0.48mm thick battens, use #10x25 wafer head Type 17 screws and reduce strength capacity above by 15%. All spans and pressures based on edge areas of wall. In some instances, better spans may be possible away from the edges. TC Terrain category. FS, PS, NS Full, partial and no shielding. Internal pressure coefficient +0.2/-0.3, external pressure coefficient -0.65. For more specific applications, AvantaLine® cladding must be designed to the pressure limitations on the next table.

AVANTALINE® CLADDING WIND PRESSURE TABLE - NON-CYCLONIC AREAS

Stramit tests to Australian Standard AS 1562.1:2018 called up in the National Construction Code to provide wind pressure tables.

The table below shows wind pressure capacity based on the direct pressure (airbox) test method.

Tables are based on testing to AS 1562.1:2018 and AS 4040 parts 0 and 2. Internal spans must have both end spans 20% shorter.

STRAMIT AVANTALINE® CLADDING WIND PRESSURE TABLE - NON-CYCLONIC AREAS											
Rib Height (mm)	Top Width (mm)	Cover (mm)	Span Type	Serviceability pressure (kPa) at the span (mm) shown				Strength pressure (kPa) at the span (mm) shown			
				450	600	900	1200	450	600	900	1200
25	285	300	Internal	2.52	2.52	1.71	0.93	4.43	3.21	2.48	1.46
			Equal	2.52	2.52	1.71	0.93	3.88	2.82	2.17	1.28
			Double	2.52	2.52	1.71	0.93	3.55	2.58	1.99	1.17

Internal spans must have both end spans 20% shorter. Values are only valid for use on steel supports 0.55mm G550 or thicker. Where thinner supports are used, fastener capacity must be checked. For 0.48mm thick battens, use #10x25 wafer head Type 17 screws and reduce strength capacity above by 15%.

SPRING CURVING

Stramit's AvantaLine® cladding is not suitable for spring curving applications. It is most important that the structure behind the AvantaLine® cladding is the one flat plane, so any installation distortions are reduced.

SHEET LENGTH FOR DESIGN PURPOSES

AvantaLine® cladding standard production maximum length is 9 metres. Longer lengths may be available however are not standard and should be discussed with Stramit before designing. Due to the nature of the interlocking profile, additional care

must be taken when manufacturing, handling and transporting long lengths. It's recommended that designs are made within the current standard lengths.

THERMAL EXPANSION

All metal sheeting is subject to thermal expansion and, where there is a temperature difference between the sheeting and the structure, this needs to be accommodated. The colour of the sheeting will affect the amount of thermal expansion and will affect its ability to resist without problems.

OIL CANNING

Wide, flat profiles may be subject to "oil canning", a perceived waviness in the material. This may happen in any wide, flat profiles and is usually an aesthetic issue only and the structural performance is not affected.

Since many uncontrollable factors are involved, no manufacturer can realistically assure the total elimination of oil canning.

With careful attention to the production and selection of material, to the panel design and to installation practice, oil canning can be effectively minimised.

To minimise the appearance of oil canning, use narrower profiles, lighter colours in matt finishes, ensure the sub structure is in a flat plane and fasteners are installed correctly.

PROCUREMENT

ORDERING

AvantaLine® cladding can be ordered directly, through distributors, or supplied and fixed from a roofing contractor.

PRICES

Prices on AvantaLine® cladding and its accessories can be obtained from your nearest Stramit location or distributor of Stramit® products. As Stramit does not provide an installation service, ask your tradesperson for a supply and fix price. Contact your nearest Stramit location for the names of tradespersons in your area.

LENGTH

AvantaLine® cladding is supplied cut-to-length. When designing or transporting long products ensure that the length is within the limit of the local Transport Authority regulations. The manufacturing tolerance on the length of product supplied is +0, -15mm.

FLAMMABILITY AND COMBUSTIBILITY

Fire resistance is such an important topic and one that we take seriously at Stramit.

Stramit® roofing, cladding, rainwater and structural building products are manufactured from steel produced by BlueScope® Steel or Pacific Coil Coaters (through Selection Steel). Both organisations have had independent tests on their materials carried out by CSIRO or AWTA. The testing was conducted in accordance with the Australian Standard AS 1530.3 'Simultaneous Determination of Ignitability, Flame Propagation, Heat Release and Smoke Release.' All materials had a surface finish less than 1mm in thickness and a Spread of Flame Index of 0. When tested in accordance with AS 5637.1 :2015, Bluescope® COLORBOND® Steel has a Product Group Number classification of 1.

Stramit® products made from these steel sources and with the tested finishes would be considered non-combustible according to NCC 2022 Volume One clause C2D10 (6)(e) and Volume Two clause H3D2 (1)(e).

It is important to note that Stramit® sheeting is only one component used in construction of these building elements, and other components must also meet the necessary requirements to satisfy the criteria.

For more information, refer to the *Stramit Flammability Guide* on stramit.com.au.

RELATED PRODUCTS



Flashings – a range of custom flashings, barge roll etc.

Refer to the *Stramit® Roof and Wall Flashing Architectural Detailing Design Guide* available on stramit.com.au



Insulation – a range of Sisalation® foil insulation, plain & foil backed blanket.

INSULATION

AvantaLine® cladding is suitable for use with insulating blanket. Glasswool blanket up to 50mm thick can be readily used. Increased thicknesses require longer fasteners and greater care in installation. Ensure the length of the screw is sufficient to have a minimum of 3 threads protruding below the steel support. For domestic applications Stramit recommends that insulation is always used.

DELIVERY/UNLOADING

AvantaLine® cladding requires additional care when transporting and unloading.

Pack mass may be up to one tonne. When lifting AvantaLine® cladding, care should be taken to ensure that the load is spread to prevent damage.

Delivery can normally be made within 72 hours, subject to the delivery location, quantity and material availability, or can be at a pre-arranged date and time.

Please ensure that suitable arrangements have been made for truck unloading, as this is the responsibility of the receiver.

HANDLING/STORAGE

AvantaLine® cladding should be handled with care at all times to preserve the product capabilities and quality of the finish. Packs should always be kept dry and stored above ground level while on site. If the sheets have become wet, they should be separated, wiped and placed in the open to promote drying.

FASTENERS FOR NON-CYCLONIC REGIONS

All fasteners with Phillips head.

One screw at each edge and lap through both layers of material per support:

 **Steel battens:** 0.48mm BMT - 10 x 25mm wafer head Type 17 screws

0.55mm BMT or greater - 10 x 16mm wafer head self-drilling screws

 **Timber battens:** 10 x 25mm wafer head Type 17 screws

INSTALLATION

AvantaLine® cladding is readily installed with or without insulation blanket.

The use of heavy-duty sarking is recommended to ensure weather tightness. If practical lay sheets in the opposite direction to prevailing weather.

Installation of AvantaLine® cladding is a straightforward procedure using the following fixing sequence.

FASTENER LOCATION

AvantaLine® direct fix cladding has the fasteners driven through both layers of each lap joint, shown as double skin fixing on the right.

SITE INDUCTION

Consideration should be given to handling and installation issues as part of site induction safety procedures. Specific consideration should be given to pack handling, avoidance of cuts, trips, slips and falls, long sheet handling particularly in windy conditions, sheet cutting procedures and surface temperature on sunny days. Personal Protection Equipment (PPE) must always be used.

GOOD PRACTICE

Stramit recommends that good trade practice be followed when using this product, such as that found in Australian Standards AS 1562.1:2018 and handbook HB39.

SHEET HANDLING

Cut resistant or leather gloves must be worn when handling product. Foot protection must be worn when handling and transporting product.

CUTTING

AvantaLine® cladding can be easily cold cut, where required, using a power saw with a steel cutting blade or a power nibbler and, for localised cutting, tin snips. Avoid the use of abrasive discs as these can cause burred edges and coating damage.

Please dispose of any off-cuts carefully.

SINGLE SKIN FIXING GROOVE
SIDE - EDGE POSITION

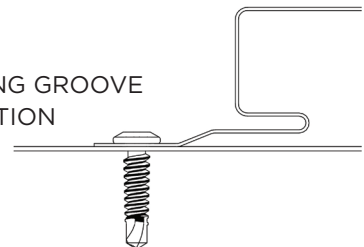

DOUBLE SKIN FIXING
- INTERMEDIATE POSITIONS

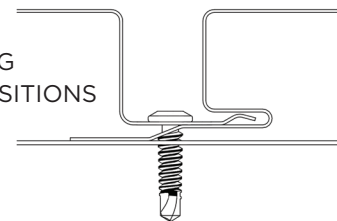

SINGLE SKIN FIXING TAB
SIDE - EDGE POSITION

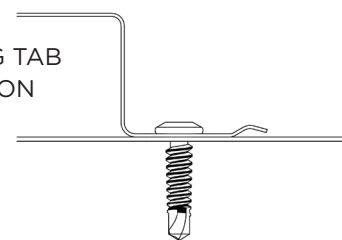

Installation steps

1. Ensure all purlins/battens are in line and correctly installed and that building wrap, plywood substrate, mesh and blanket (if specified) are in place. Note plywood substrate may not be accepted in bushfire prone areas.
2. Position the first sheet ensuring correct overhangs and fix the trailing edge to each support using the nominated fastener. Ensure screws are not over tightened.
3. Carefully insert the trailing edge of the next sheet into the groove in the leading edge of the former sheet. Ensure a uniform gap of 15mm is maintained between the vertical upstands of the two sheets by using spacers or similar. Any variation in the gap will be visible, care must be taken to ensure it is uniform.
4. Fix the two sheets down with a single screw at each support, ensuring both layers are fixed down as indicated in double skin fixing diagram.
5. Continue to install subsequent sheets checking that the sheet ends are aligned and the 15mm gap between the sheet upstands is maintained.
6. Measure the overall cover width at the top and bottom of the sheets from time to time to avoid "fanning".
7. Install flashings as necessary to ensure weatherproof solution. Fix flashings according to AS 1562.1:2018.
8. Clean up after each day's work, removing all screws, cuttings, swarf etc and leave area clean.

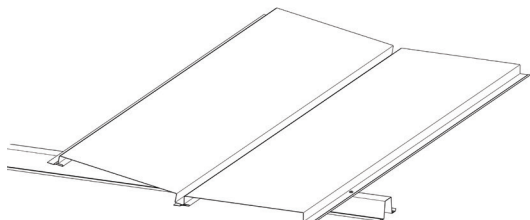

Note: the different cover width versions of AvantaLine® cladding can be used together to create different architectural appearances.

END LAPS

End lapping of AvantaLine® cladding is not recommended. Contact Stramit Technical Services for more information.

CLOSED ENDS

Panels can be supplied with one end closed and the other end notched out and ready to be folded down.

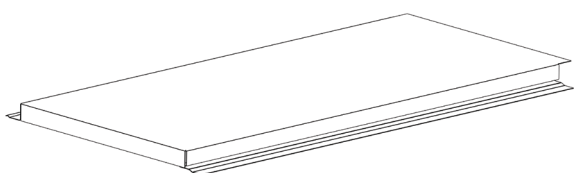

TYPICAL FLASHING DETAIL

See below for typical corner flashing detail.



For more flashing detail, refer to the *Stramit® Roof and Wall Flashing Architectural Detailing Design Guide* available on stramit.com.au.

ADDITIONAL INFORMATION

MAINTENANCE

Exterior surfaces of metal products unwashed by rain can benefit from occasional washing to remove build-up of corrosive salts. Walls beneath eaves or awnings are such a situation.

FURTHER INFORMATION

As well as our standard range of Technical Manuals, Installation Leaflets, Case Studies and other promotional literature Stramit has a series of Guides to aid design.

REFERENCES

In preparing this document reference has been made to:

- Standards Australia Handbook - HB39 (Installation code for metal roof and wall cladding)
- BlueScope Steel - Technical Bulletin TB-4 (Maintenance of exterior BlueScope® coated steel products)
- BlueScope Steel - Technical Bulletin TB-1 (Steel roofing and walling products - selection guide)

CONTACT US

Visit [stramit.com.au](https://www.stramit.com.au) or contact us using the details below.

REGION	LOCATION	CONTACT DETAILS	TECHNICAL ENQUIRIES
NSW & ACT	SYDNEY 33-83 Quarry Rd, Erskine Park NSW 2759	Ph 02 9834 0909	Ph 02 9834 0964
	CANBERRA 4 Bass St, Queanbeyan NSW 2620	Ph 02 6298 2500	
	COFFS HARBOUR 6 Mansbridge Dr, Coffs Harbour NSW 2450	Ph 02 6656 3800	
	NEWCASTLE 17 Nelson Rd, Cardiff NSW 2285	Ph 02 4041 3400	
	ORANGE 51 Leewood Dr, Orange NSW 2800	Ph 02 6360 9200	
VIC	MELBOURNE 3/1464 Ferntree Gully Rd, Knoxfield VIC 3180	Ph 03 9237 6300	Ph 03 9237 6353
	ALBURY 18 Ariel Dr, Albury NSW 2640	Ph 02 6092 3700	
	BENDIGO Lot 7-9 Ramsay Court, Kangaroo Flat VIC 3555	Ph 03 5448 6400	
TAS	HOBART 57 Crooked Billett Dr, Brighton TAS 7030	Ph 03 6262 8788	Ph 03 9237 6353
SA	ADELAIDE 11 Stock Rd, Cavan SA 5094	Ph 08 8219 2000	Ph 08 9493 8823
SOUTH QLD	BRISBANE 57-71 Platinum St, Crestmead QLD 4132	Ph 07 3803 9999	Ph 07 3803 9869
	MARYBOROUGH 10 Activity St, Maryborough QLD 4650	Ph 07 4123 9500	
	ROCKHAMPTON 41 Johnson St, Parkhurst QLD 4702	Ph 07 4921 5600	
NORTH QLD	CAIRNS 53 Vickers St, Edmonton QLD 4869	Ph 07 4034 6555	Ph 07 3803 9869
	TOWNSVILLE 402-408 Bayswater Rd, Garbutt QLD 4814	Ph 07 4412 3900	
WA	PERTH 605-615 Bickley Rd, Maddington WA 6109	Ph 08 9493 8800	Ph 08 9493 8823

Talk to your local Stramit account manager to find out more.

Please contact us at techsupport@stramit.com.au
for product installation instructions and further technical support.

© 2023 Stramit Corporation Pty Limited ABN 57 005 010 195. A member of the Fletcher Building Group. Use of * indicates trade marks of Stramit Corporation Pty Limited. This document replaces all previous issues. Please destroy, or clearly mark as superseded, all previous issues. COLORBOND® and ZINCALUME® are registered trade marks of BlueScope Steel Limited. ABN 16 000 011 058. Sisalation® is a registered trademark of Fletcher Insulation Pty Ltd. UniCote® is a registered trademark of Selection Steel Trading Pty. Ltd. STR091_DEC23.