

CONDENSATION MANAGEMENT FOR STEEL ROOFING

**Principles and approaches for managing
moisture in Australian residential steel roof systems**

CMST V12-INDUSTRY 23



AUSTRALIAN STEEL INSTITUTE

CONTENTS

DOCUMENT PURPOSE	2
THE INCREASING NEED FOR MOISTURE MANAGEMENT IN BUILDINGS	3
WHAT IS CONDENSATION AND WHEN IS IT A PROBLEM?	3
DESIGN PRINCIPLES FOR MOISTURE MANAGEMENT IN ROOFS	4
EFFECTIVE VENTILATION OF ROOFS	4-6
ROOF LEVEL INSULATION REDUCES THE RISK OF CONDENSATE FORMING	6
CONSIDERATIONS WHEN DETERMINING APPROACH TO MOISTURE MANAGEMENT IN ROOFS	6-7
CONDENSATION MITIGATION APPROACHES FOR STEEL ROOFING	8
TYPES OF STEEL CLAD ROOF SYSTEMS AND HOW THEY MITIGATE CONDENSATION RISK	9-11
DURABILITY	11
CASE STUDIES	12-14
DEFINITIONS	14
NASH, ASI & CONTACTS	15

DOCUMENT PURPOSE

Lightweight steel building products including roofing, walling, framing and insulated sandwich panels are versatile and can be applied in different construction approaches to meet the growing demands of energy efficiency and condensation management in residential buildings.

The purpose of this document is to:

- Outline key principles for moisture management of steel roof systems.
- Discuss different approaches for typical Australian roofing systems and how these relate to the principles and considerations presented.
- Highlight factors to consider when determining approaches to managing condensation risk.
- Demonstrate how solutions for mitigating condensation can be easily and successfully assembled as part of a broader steel roofing system solution which meets other functional, performance and design requirements such as thermal, bushfire, weatherproofing etc.

Understanding principles and how these translate to various approaches to managing condensation, will assist designers appropriately detail steel roofing systems. For further practical guidance for meeting requirements in cooler climates refer to “Ventilation in Steel Roofing” (climate zones 6,7 & 8) in this series.



AUSTRALIAN STEEL INSTITUTE

THE INCREASING NEED FOR MOISTURE MANAGEMENT IN BUILDINGS

Modern construction techniques, increased insulation levels, tighter sealed buildings, and new materials to meet energy efficiency in the National Construction Code (NCC) has led to additional approaches being necessary to mitigate the higher risk of moisture related issues in buildings. This especially applies to buildings in the colder climates of Australia which have a higher condensation risk and less favourable conditions for drying of the building envelope.

These construction changes impact the natural ventilation and drying capacity of buildings to manage the internal water vapour and moisture generated by occupancy. In recognition of this, the NCC has introduced additional requirements relating to moisture management in walls and roofs of residential buildings.

While the NCC requires peak moisture loads generated from wet areas like bathrooms and kitchens be managed by discharging directly

to outdoor air, some practical measures are still required to manage internal water vapour and control interstitial condensation risk in walls and roofs.

The choice of materials, products and construction approach will influence how a roof system is able to manage moisture. The roof system therefore needs to consider material durability and compatibility, as well as compliance with manufacturer warranties and consideration of practical and safe installation methods.

In this document, simple and practical measures to enable the natural drying capacity of roofs are suggested which are broadly aligned with British Regulation BS5250:2021 (Management of Moisture in Buildings: Code of Practice). Customisations have been applied to incorporate consideration of Australian climate and typical construction practices.

WHAT IS CONDENSATION AND WHEN IS IT A PROBLEM?

Condensation occurs when water changes state from a vapour into a liquid. For condensation to occur it requires two sets of conditions:

1. The presence of water vapour in the air.
2. A cold surface that is below the dew point of the air.

Certain activities can substantially add to the amount of water vapour inside a house, such as showering, cooking, the use of washing machines, clothes dryers, dishwashers and even the presence of people.

Condensate is commonly seen on internal surfaces that are colder than the dew point, like glass windows on a cold night, or from showering in bathrooms as fogging or water droplets.

Condensate may also occur in less visible areas that may go unnoticed, such as on the underside

of a roof system or in a wall system, this is known as interstitial condensation.

Generally small quantities of condensate in a building can be tolerated provided it doesn't accumulate and cause sustained problematic wetting of the building fabric or sensitive materials. Avoiding accumulation of moisture requires a system that dries and/or drains more moisture than is generated.

Condensation in roofs can become problematic, particularly in cold climates, when condensate is unable to adequately dry due to inadequate ventilation and/or drain due to inadequate detailing. In most cases practical measures can be implemented to maintain the drying capacity of roofs and prevent the long term accumulation of moisture.

DESIGN PRINCIPLES FOR MOISTURE MANAGEMENT IN ROOFS

Principle 1. Keep moisture out of the roof system

This principle relates to keeping rain out and limiting internal moisture from entering the roof system. Steel roofing systems provide effective and compliant weatherproofing for buildings. Limiting internal moisture from entering the roof involves

limiting high internal humidity by ventilating living spaces, direct external exhausting of peak moisture generating sources like bathrooms, and limiting ingress of water vapour using airtight internal linings and/or vapour control layers.

Principle 2. Allow moisture that enters to escape

Moisture can inevitably get in and when it does it must be able to escape without consequential issues for occupant health and damage to materials.

to escape requires designing a roof system that allows for drying and/or drainage. Drying may be achieved via the creation of a ventilated air space. Drainage can be achieved with gravity and appropriately designed systems.

Steel roofing is impermeable to air, water, and water vapour and therefore to allow moisture

Principle 3. Minimise the risk of condensate forming

The application of roof level insulation can keep internal surfaces of roofs warmer in cold conditions reducing the risk of condensate forming.

roof sheeting. The higher the R-Value of roof level insulation the lower the risk of condensate forming. Including roof level insulation commonly involves the application of a draped thermal membrane to create a reflective air gap. Higher level protection can be achieved with insulative blanket and foil.

This principle has long been recognised within the steel roofing industry and it is common practice to include roof level insulation when installing steel

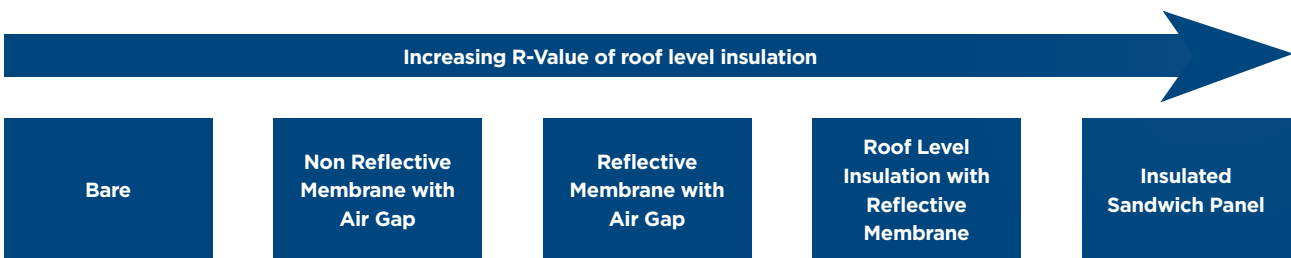

EFFECTIVE VENTILATION OF ROOFS

A ventilated air space can be highly effective at drying moisture in a roof. The ABCB Housing Provisions Standard prescribes roof space ventilation as a condensation mitigation approach.

Effective roof space ventilation requires consideration of the location and distribution of ventilation openings and unrestricted airflow. Designing with this in mind will ensure that moist air vented from the roof space is replaced with outdoor air and avoid dead pockets of stagnant air in the roof space. Following are some key principles of ventilating a roof:

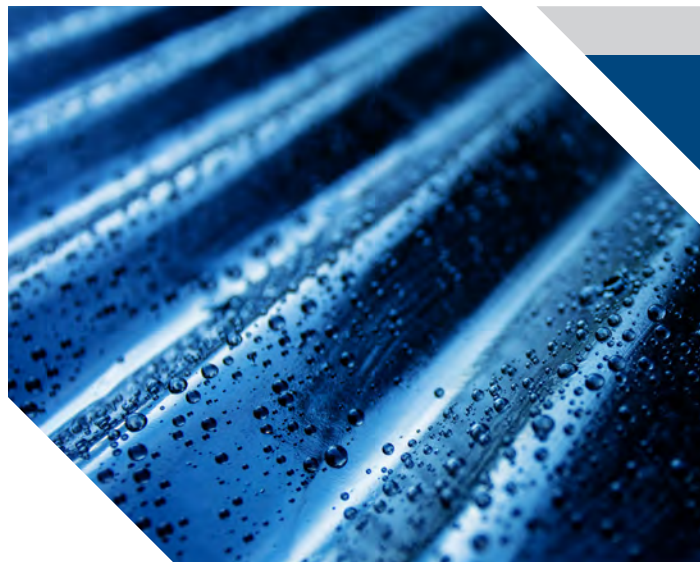

Principle 1. Low level ventilation should be larger than the high level ventilation

Having openings which create larger amounts of ventilation at the low level will ensure that outdoor air will be drawn in to replace the moist air. An imbalance could create a suction and draw warm

and moist air from the living space into the roof. This may lead to a greater condensation risk in the roof and heating or cooling losses reducing the energy efficiency and comfort of the home.

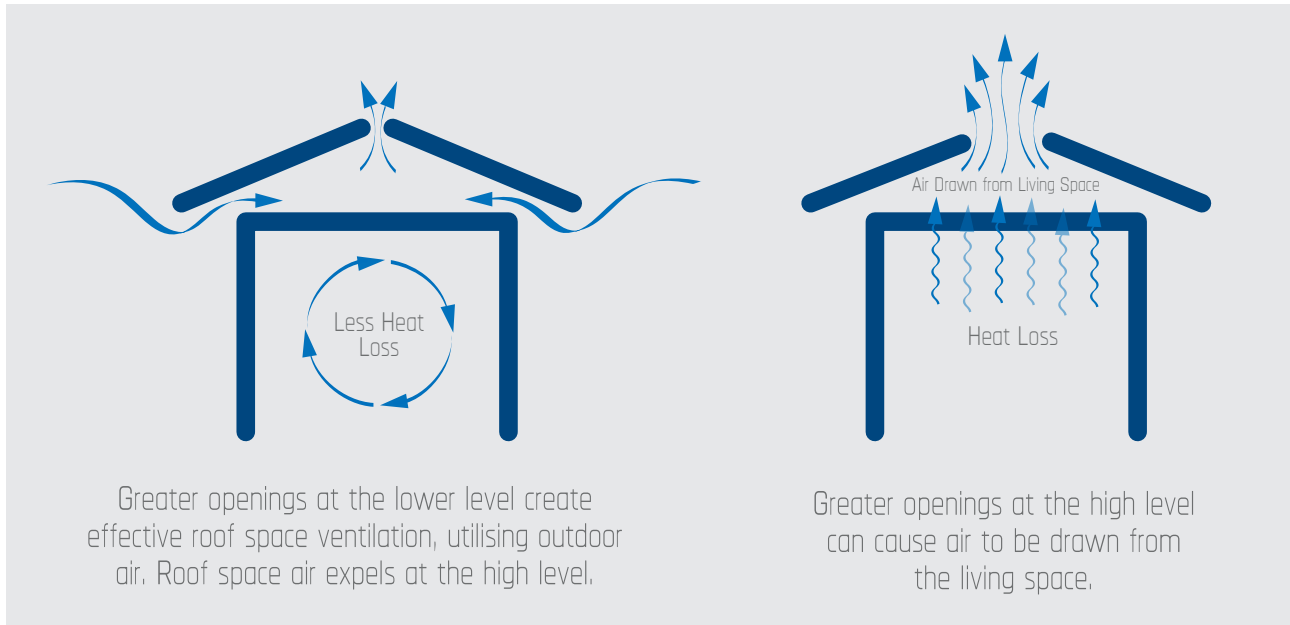

Principle 2. Ventilation should be distributed to avoid pockets of stagnant air

Even and considered distribution of ventilation openings is important to create adequate ventilation pathways to avoid pockets of stagnant

air in the roof space. This is increasingly important when considering condensation risk of complicated roof spaces and/or roof space HVAC systems.

Principle 3. Air gap providing unrestricted airflow

The roofing layer at times will be the coldest part of the roof structure and at greatest risk of condensation forming. Separation of the colder roof layer from the primary insulation via an airgap introduces robustness, allowing natural airflow for

drying and the removal of excess moisture. The airflow path must provide unrestricted air flow. Whilst the airflow path can deviate and be convoluted the air gap height should not be less than 20mm. Examples follow for a pitched and skillion roof.

Pitched Roof

A large roof space is inherent in a pitched roof with a flat ceiling.

A 20mm gap is required between the underside of the roof system (cladding, roof insulation or sarking) and the ceiling insulation, particularly near the external wall junction. Approaches that may assist to meet the air gap height are using thinner perimeter insulation batts or vent devices (e.g. baffle).

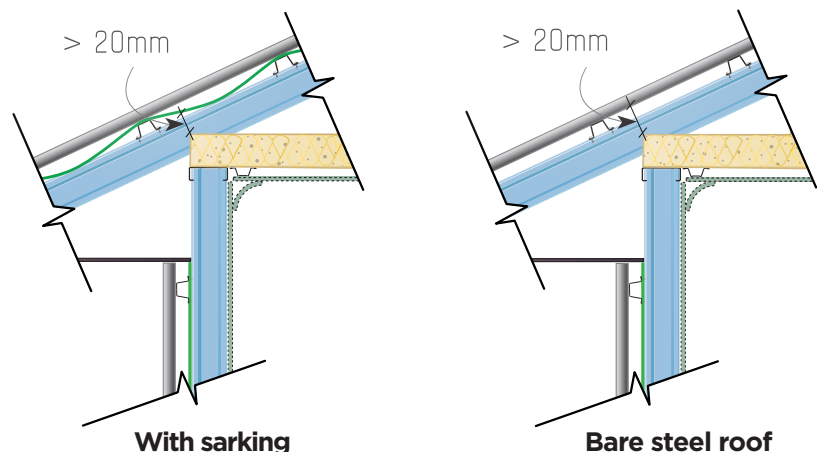

Skillion Roof

In a skillion roof where the primary insulation is in line with the roof plane, a minimum 20mm space needs to be maintained between the insulation and the underside of the roof system.

Where the ceiling insulation thickness is 20mm below the top of the rafter, a gap is naturally created (Figure b).

Where the ceiling insulation thickness is the same depth as the roof rafters a preferred approach is to increase the rafter depth (Figure c). Alternatively, introducing a spacer batten, packer or ventilation device can also be effective.

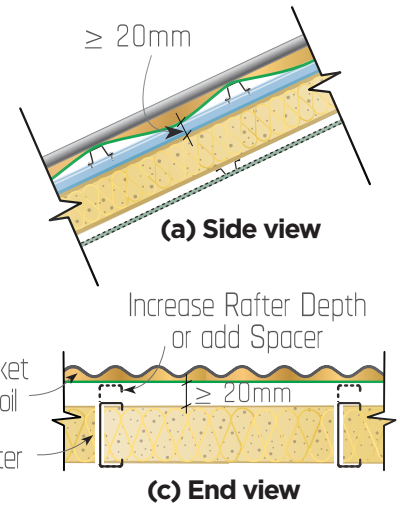

ROOF LEVEL INSULATION REDUCES THE RISK OF CONDENSATE FORMING

Condensation can occur on the underside of roofs. On cold clear still nights, roofs typically drop beneath the outdoor ambient temperature. If the roof is both in contact with the roof space air, and its temperature is beneath its dew point, condensate will form.

The use of an impermeable membrane reduces the risk of condensate forming on the underside of the roof sheet by acting as a barrier to water vapour in the roof space. As shown in Figure 1, the use of blanket and foil is one of the most effective approaches to reduce condensate forming.

Using roof level insulation can keep internal surfaces of roofs warmer in cold conditions to reduce the risk of condensate forming.

Figure 1. As can be seen in these 2 scenarios, the use of blanket and foil (in this case 55mm) keeps the internal surface facing the roof space warmer, reducing the risk of condensate forming (temperatures were determined through empirical calculations based on steady state conditions).

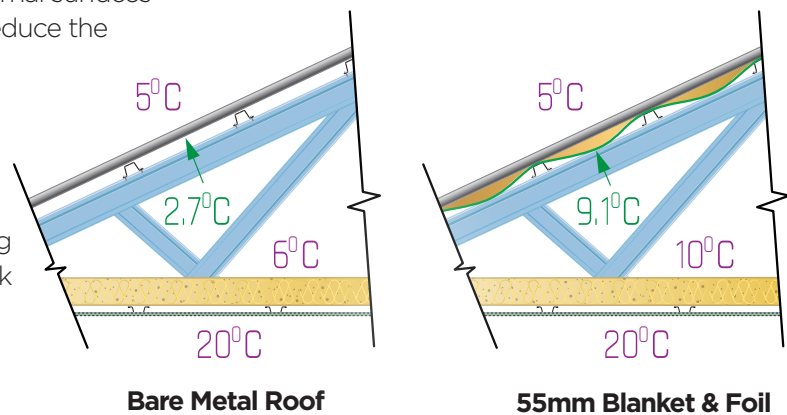

CONSIDERATIONS WHEN DETERMINING APPROACHES TO MOISTURE MANAGEMENT IN ROOFS

Building materials can be assembled in different ways to achieve the desired functions of a roof system, be it weather tightness, appearance, structure, fire resistance, thermal performance and condensation management.

occur via diffusion through permeable materials, however significant quantities of water vapour can also be transported by air movement and ventilation.

How heat and moisture transfers through different roof systems is complex. Water vapour transfer can

Different roof types can require different approaches to mitigate the risks of moisture accumulation.

ROOF DESIGN AND ROOF PITCH

Roof design and pitch both play a role in the condensation risk of a roof. Increased roof pitch improves the natural draining potential to avoid accumulation of water (be it from rain or condensate). Increased roof pitch also creates the opportunity for improved air movement, ventilation and drying potential via larger roof spaces and buoyancy flow.

A pitched roof with a flat ceiling is the most robust of the roof systems, having a large airspace helping to absorb and mitigate moisture loads.

Additional consideration of moisture protection measures can be necessary for low pitch skillion or cathedral roofs, particularly in cold climates. In these cases, roof level insulation may help reduce the risk of condensate forming.

Drying Mechanism	Pitched Roof Flat Ceiling	Pitched Cathedral Roof	Low Pitched Cathedral Roof
Natural Drainage Potential	✓	✓	Limited
Buoyancy Flow	✓	✓	Limited
Large Airspace	✓	Limited	Limited

TYPE OF ROOF CLADDING MATERIAL

The type of roof cladding material can influence the design approach to managing moisture risk.

Steel sheet cladding is impermeable and considered to be **Air & Vapour Closed**.

Roofs clad with **tiles or shingles** are typically considered to be **Air & Vapour Open**.

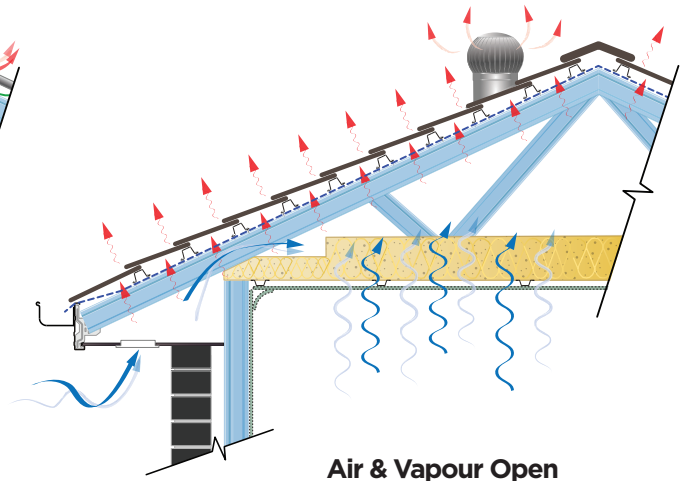
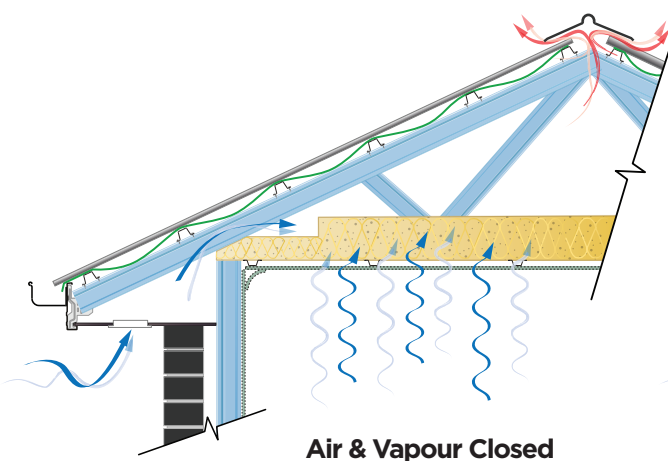

Condensation mitigation and the transfer of water vapour from a roof space through an **Air & Vapour Closed** roof system is different from an **Air & Vapour Open** system. Roof space ventilation provides an effective approach in **Air & Vapour Closed** roof systems to mitigate condensation risk and keep the roof space dry.

In Australia, steel sheet roofing installed to AS1562.1 and supported by SA HB39 is considered **weatherproof** and a sarking membrane is not typically required to manage external water ingress or function as a secondary drainage plane.

CONDENSATION MITIGATION APPROACHES FOR STEEL ROOFING

There are many approaches to designing a steel roof that are aligned with condensation mitigation principles.

The approach should consider the condensation risk of the external environment and the inherent risk of the roof and building design.

A steel roof will have inherent characteristics that may assist with mitigating condensation risk such as trickle ventilation. For lower risk climates the gaps provided by the steel cladding profile at the fascia and ridge (as shown in images 1 & 2) may provide sufficient ventilation of the roof space.

One of the benefits of steel clad roof systems is their design flexibility. Conventional approaches can meet condensation management requirements while providing additional functionality. An example of this is the provision of ventilation plus roof level insulation. This provides a robust condensation mitigation measure for steel roofs in higher risk climates. It also provides enhanced thermal comfort for occupants and improves the energy efficiency of the building.

Higher condensation mitigation performance can be achieved by increasing levels of roof insulation and/or ventilation. Increased ventilation approaches include: dedicated ventilation air gaps, eave and ridge vents and/or mechanical vents (whirlybirds)



Examples of trickle ventilation (1) at the eave (low level) and (2) the ridge (high level)



TYPES OF STEEL CLAD ROOF SYSTEMS AND HOW THEY MITIGATE CONDENSATION RISK

Different roof types employ specific strategies to effectively manage and reduce condensation risk, including providing additional functional benefits.

Bare Steel Clad Roof

A bare steel clad roof serves the dual purpose of providing weatherproofing and structural support. Adequate ventilation is crucial to remove water vapour from the roof cavity and to dry any condensate from its underside should it form. The gaps between the steel cladding profiles facilitate natural ventilation and thermal buoyancy, enabling outdoor ventilation from the eave to the attic. In most situations this ventilation process efficiently dries overnight moisture.

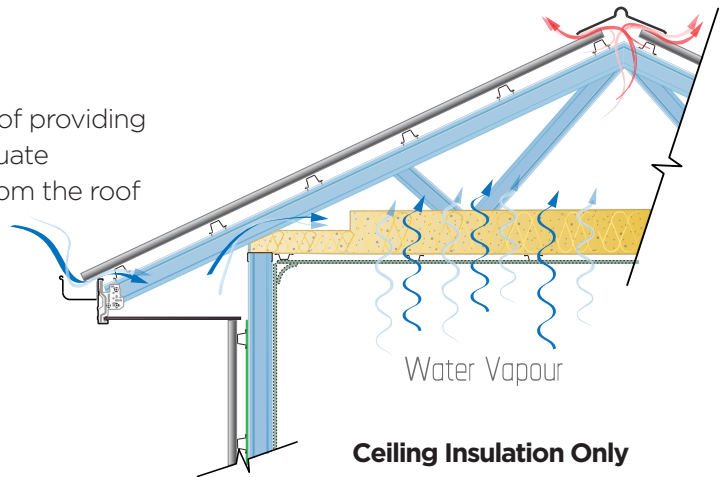

Steel Clad Roof with Roof Level Insulation

The inclusion of roof level insulation minimises the risk of condensate forming within the roof cavity in combination with roof space ventilation. The system relies on:

- an **impermeable membrane** to restrict water vapour from the attic reaching the underside of the steel cladding keeping the environment above the membrane dry and
- insulation above the membrane** to insulate the membrane from the steel clad sheet in cold weather reducing condensation risk.

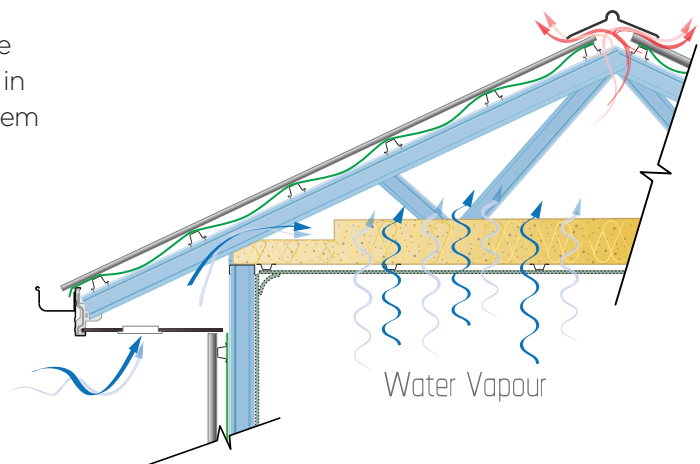

Roof level insulation can enhance building energy efficiency and thermal comfort. In addition, a steel clad roof with insulation can provide increased bushfire resistance and improved acoustic performance.

There are different roof level insulation options available. A common option is a reflective pliable membrane, which acts as a thermal control layer, vapour retarder, and provides fire resistance. The membrane may also have inherent insulation properties, such as foam or bubble foil. Another common option is a blanket and foil product, which serves as a thermal control layer, condensation mitigation layer, vapour control layer, acoustic dampening layer, and fire-resistant layer.

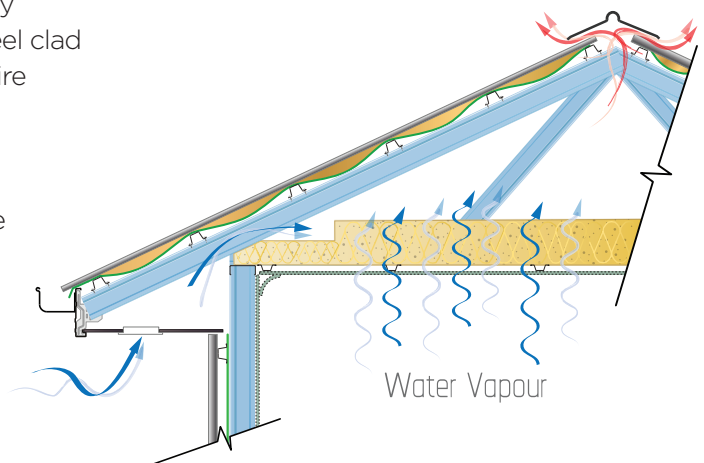

Steel Clad Roof with Permeable Membrane

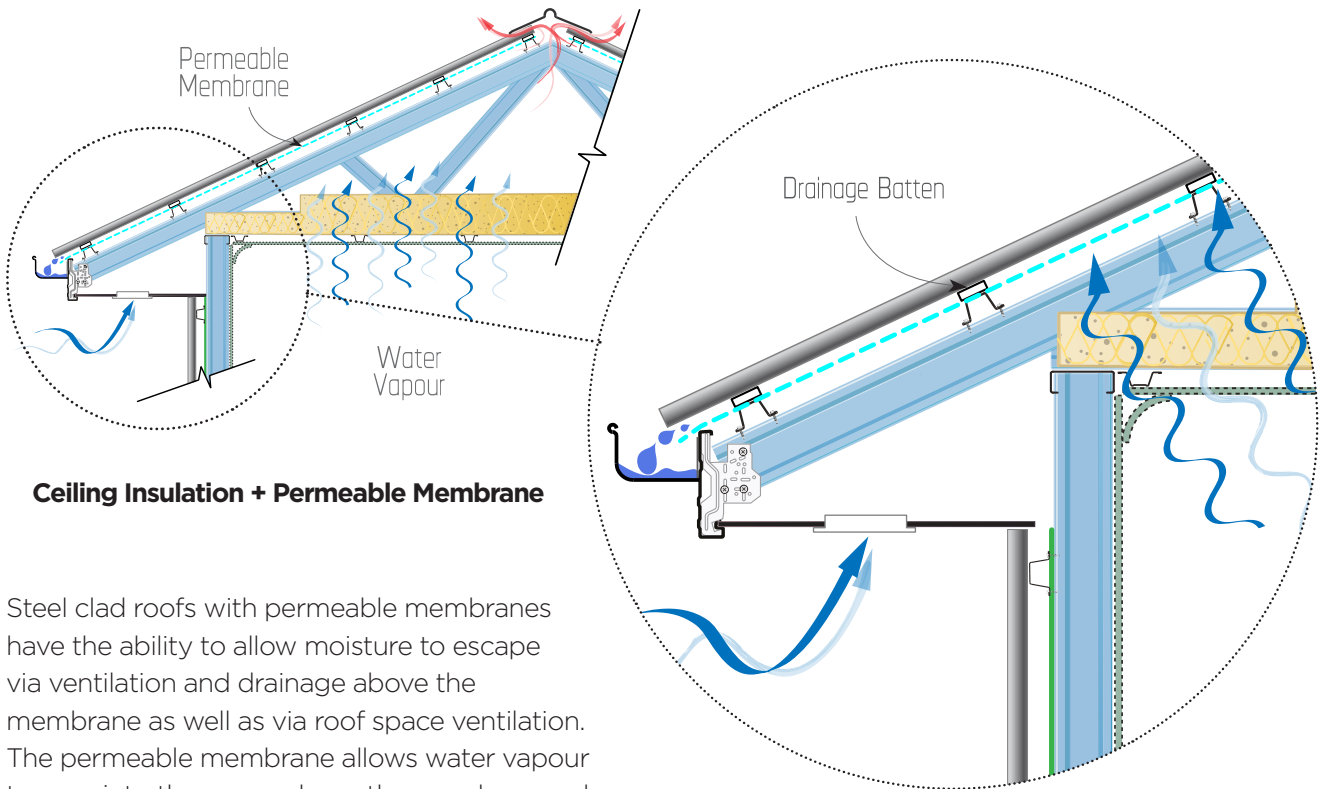

Ceiling Insulation + Permeable Membrane

Steel clad roofs with permeable membranes have the ability to allow moisture to escape via ventilation and drainage above the membrane as well as via roof space ventilation. The permeable membrane allows water vapour to pass into the space above the membrane, where it either ventilates out the ridge or condenses on the cold underside of the roof cladding and is drained to the gutter.

Factors to consider when using a permeable membrane include:

- the need for free drainage to the gutter, such as installing the membrane taut or with rigid support, a higher pitch to facilitate drainage, and the absence of any obstructions.
- separation of the membrane from the underside of the cladding to facilitate drying may be required
- consideration of the durability of components above the membrane due to the potential greater presence of moisture.

Permeable membranes are often used in conjunction with air control membranes on internal linings for increased energy efficiency performance. Consequently this approach is more widely used for achieving the Passivhaus (TM) standard.

Insulated Sandwich Panels

Insulated Sandwich Panels (ISPs) provide an effective continuous plane of insulation for high thermal performance aligning the internal and external surface temperatures with the immediate surroundings. This, in turn, reduces the likelihood of surface condensation formation.

An ISP roof system serves the purpose of keeping moisture out and minimizing condensate formation within. Being a single building element comprising of an impermeable insulating core sandwiched between two layers

of steel skins which are water, air and vapour impermeable, ISPs are not normally susceptible to interstitial condensation.

If installed correctly, ISPs can maintain extremely good levels of water and vapour resistance, mainly due to their joint design and assembly methods, which often incorporate foam or sealants as well as interlocking or overlapping connections.

ISPs used for roofing will need to have ventilation appropriately designed in association with the air tightness of the wall type.

Airtight constructions will require mechanical ventilation for water vapour to be regulated in the living space. Walls with inherently less air tightness such as brick veneer may not need additional ventilation provisions. For further information refer to the manufacturer for design and installation guidance.

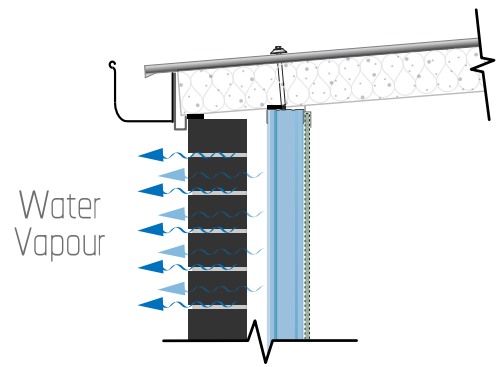

Temporary Moisture Storage - Absorbent Fleece Material

The temporary moisture storage system utilizes absorbent fleece material to reduce and mitigate the effects of condensation in combination with allowing moisture to escape via roof space ventilation.

The inherent insulation of the fleece material slightly reduces the risk of condensate forming and the fleece stores any condensate that may develop.

The system takes advantage of warmer daytime drying conditions to convert the stored water in the fleece back into a vapour state. This allows the moisture to escape by natural ventilation forces, promoting effective moisture management.

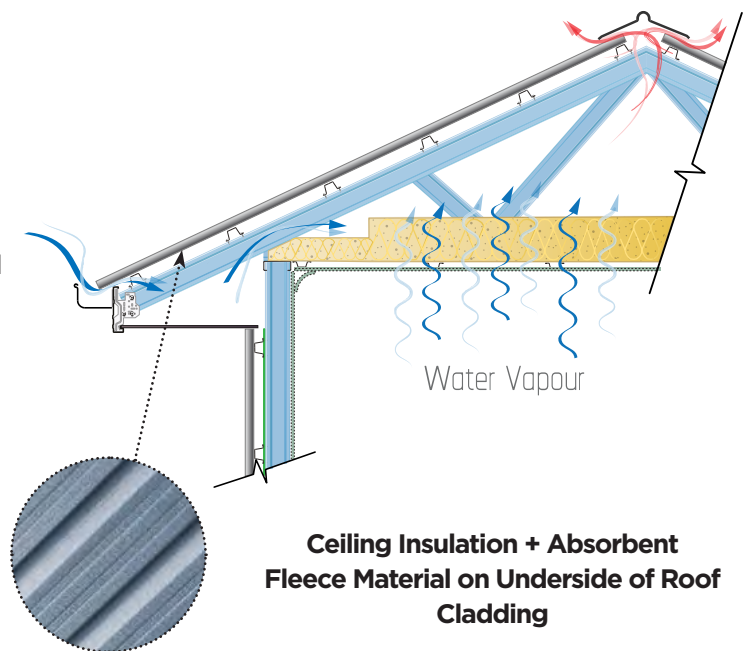

DURABILITY

Considerations for Permeable Membrane Approaches in Steel Roof Applications

To meet the design life of a roof, all components must be durable and compatible.

The use of permeable membranes with steel clad roofing in Australia is relatively new. Unlike a conventional impermeable membrane, permeable membranes require consideration of the durability of components above the membrane. This is to:

- allow moisture above the membrane creating a more humid micro-climate.
- require drainage above the membrane.
- require ventilation above the membrane that may create higher corrosive aerosols, particularly in marine and industrial areas.

The risk from moisture and corrosive aerosols in the cavity above a permeable membrane may impact the choice of components, such as steel cladding, structural roof battens, fasteners, vent devices and any separation materials. It is important to select materials that are durable, including consideration of their compatibility and building component warranty conditions.

NOTE: The structural integrity of the roof relies upon the durability of structural roof battens and fasteners.

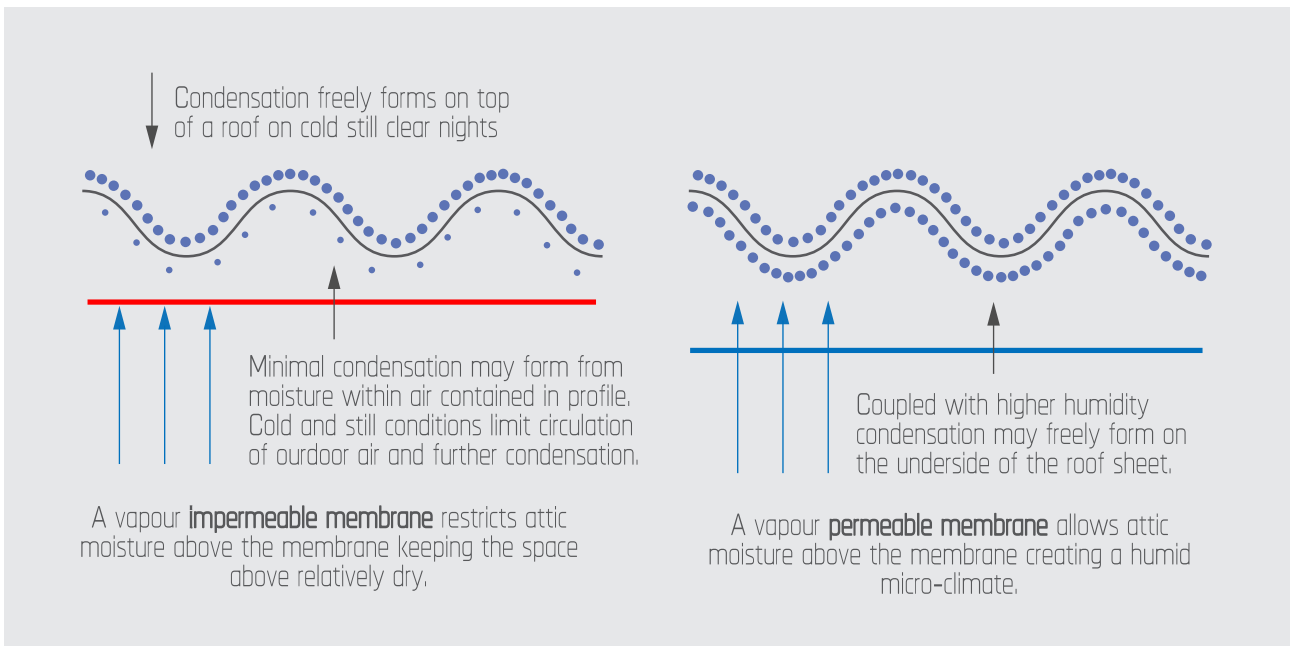

Permeable membranes can create a more humid micro-climate above the membrane

CASE STUDIES

WHAT CAN HAPPEN ON THE UNDERSIDE OF A STEEL ROOF

On cold, clear and still nights across Australia it is common to see condensation form on the top surface of roofing.

Exposure to clear night skies can cause the surface temperature of the metal roof to fall below the dew point, and moisture contained in the external air will condense on the roof surface. This may raise the question, **what happens on the underside of metal roofing?**

In the case of metal roof structures such as open sheds, carports, verandas and awnings where the external night air can freely circulate underneath the roof, condensation on the underside of the cold metal roof sheeting is expected.

In the case of a metal roof in typical housing construction, the internal roof structure is effectively separated from the moist external air. On cold and still nights when condensation is most likely to occur, the absence of wind and significant thermal stack effect results in very still conditions underneath the metal roofing. Very little moist air is likely to circulate under ridge flashings and down along profiled metal sheeting, thereby avoiding a scenario of moisture condensation on the underside of the metal roof.

Steel roofing industry studies and field observations have demonstrated that in typical housing construction, external air is restricted from entering the roof space and thereby avoiding significant levels of condensation formation.

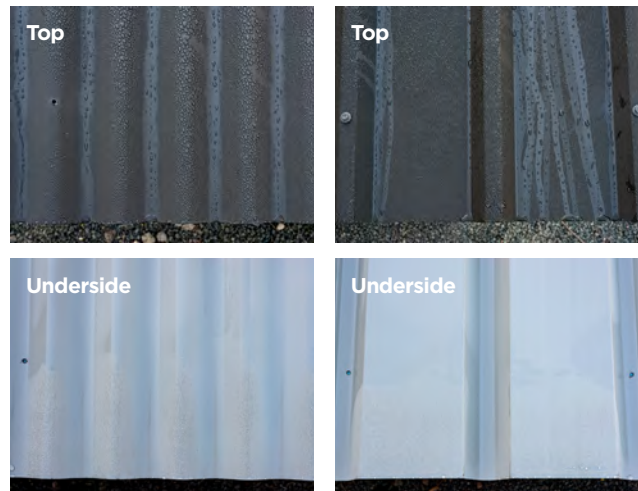

Much lower condensation occurs on the underside of steel roofs

Where a pliable membrane vapour barrier is installed underneath metal roofing and draped to create an air gap to thermally protect from the cold roof sheet, the possibility of internal moisture reaching the underside of the metal roof sheeting is further restricted.

DRYING CAPACITY OF STEEL ROOFS AND COLOUR

Whilst roofs can be exposed to conditions on clear still nights where condensate may form in the roof system, roof spaces typically warm during the day driving evaporation and air movement for effective drying of any overnight condensate.

All roofs with ventilation and drainage typically have higher drying potential than required to avoid the accumulation of moisture. A darker colour roof can also increase drying potential. A higher solar absorptance (darker colour) roof has higher daytime temperatures creating higher drying potential that may be beneficial in higher condensation risk cases, such as where there is:

- **High internal moisture** - Buildings that contain activities that produce high levels of internal moisture, such as swimming pools.
- **Shaded roofs** - Buildings that have roofs that are shaded for months.
- **Cold climates** - Cold climates that lack warm to hot summers impacting roof drying capacity.

The figure below shows the typical higher drying capacity of a roof, noting that the wetting potential is not impacted by roof colour.

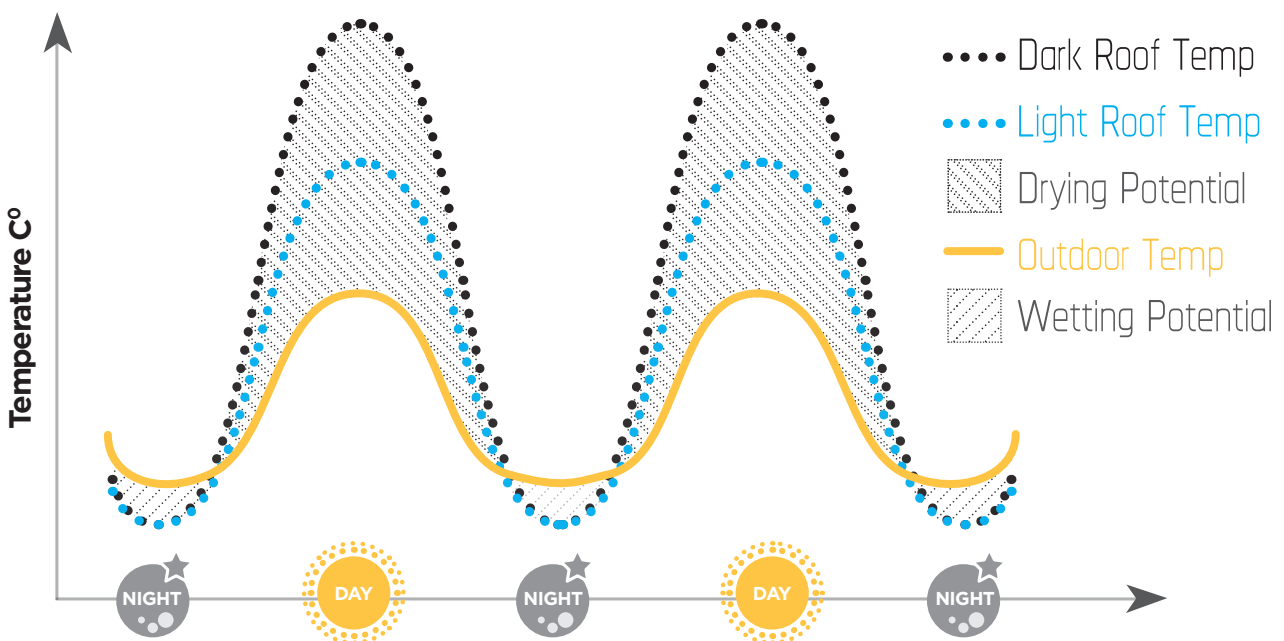

PREDICTING LONG TERM MOISTURE PERFORMANCE IN BUILDINGS.

Moisture in buildings is the result of complex interactions between the environment, the building design and construction including the use of the building and its occupant's behaviour. As such, predicting the long term likelihood of moisture accumulation and associated impacts is both challenging and imprecise.

Hygrothermal modelling is a software simulation tool used to analyse the behaviour of building components, like walls or roofs, in relation to the flow of heat and moisture.

Hygrothermal modelling tools can be used to predict locations in assemblies where moisture may pose a higher relative risk. In addition, simulations can help inform design strategies to reduce moisture risk.

Hygrothermal modelling is recognised as a verification tool to demonstrate compliance to the performance requirements for condensation management in the NCC. The application of this verification method pathway is mostly used for complex building designs (where risk is generally higher) and/or stringent

performance is required. Most construction will meet NCC compliance using prescriptive requirements that follow good practice principles.

Hygrothermal modelling necessarily makes many simplifying assumptions including around the complex interactions and transient behaviours that occur in the real world.

It is therefore very important that the results are interpreted within the context of the modelling

assumptions and inputs on which they are based. Hygrothermal modelling tools have been used by engineers and building designers for many years, however tools are still evolving. Handling of complex geometries, air flow patterns, transient behaviour and thermal interactions are still to be resolved using hygrothermal modelling. The steel industry via the Steel Research Hub program is currently undergoing research to better understand performance of Australian construction that may help improve modelling practice.

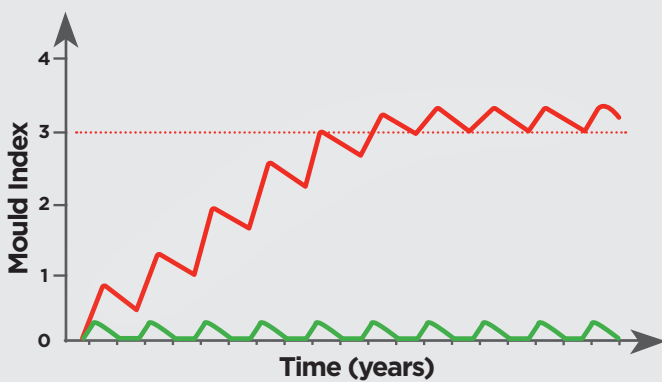

Hygrothermal modelling may be used to verify performance in the NCC by predicting the risk of mould growth on internal building elements over a nominal long term period. For NCC compliance a determined mould growth over 10 years can not exceed an index of 3 out of 5.

The output of modelling can show the predicted cumulative effect of long term wetting and drying cycles over many years. The red line shows a situation where longer term wetting exceeds the ability to dry and the accumulation of moisture results in a mould index exceeding the limit. The green line shows a situation where the drying in the system exceeds the wetting and moisture accumulation and mould growth is not sustained.

DEFINITIONS

- Dew point – the temperature below which water vapour condenses on a surface.
- Humidity – a quantity representing the amount of water vapour present in the air at a particular temperature.
- Impermeable – a material that will prevent the transmission of water, vapour and liquid.
- Moisture – water in liquid or vapour form.
- Natural ventilation forces – such as wind or heat buoyancy in a roof space that creates ventilation, allowing water vapour to escape.
- National Construction Code (NCC) – Australia’s primary set of technical design and construction requirements for buildings.
- Permeable – a material that allows the transmission of water vapour.
- Thermal resistance – a quantification of a materials resistance to heat flow.
- Trickle ventilation – natural ventilation made accessible through inherent gaps often present in construction, such as under or over a steel roof profile.
- Whirlybird – a semi-mechanical vent comprising a cylindrical dome with blades that spin in the wind creating a vacuum, drawing out air from the roof cavity.



NASH is an Australian industry association representing the interests of fabricators, material suppliers and customers of cold-formed steel structural framing systems for residential and similar construction. NASH develops Standards, Handbooks and Technical Notes for use by the industry and NASH Standards are referenced as Deemed-to-Satisfy solutions in the National Construction Code.

Contact NASH: +61 3 9809 1333
info@nash.asn.au
visit: www.nash.asn.au



AUSTRALIAN STEEL INSTITUTE

The Voice of Australian Steel

The Australian Steel Institute (ASI) is the nation's peak body representing the entire Australian steel supply chain from the manufacturing mills right through to end users in building and construction, heavy engineering and manufacturing.

Disclaimer

The information presented by the ASI, NASH and BlueScope Steel Limited has been sourced and prepared for general information only and does not in any way constitute recommendations or professional advice to any person for any purpose. While every effort has been made and all reasonable care taken to ensure the information contained is accurate and current, this information should not be used or relied upon for any specific application without investigation and verification as to its accuracy, currency, completeness, suitability and applicability by a competent professional person.

The Australian Steel Institute Limited, National Association of Steel Framed Housing Inc. and BlueScope Steel Limited, its officers, employees, consultants and contractors and the authors and editors of the publications contained on this website do not give any warranties or make any representations in relation to the information provided herein and to the extent permitted by law (a) will not be held liable or responsible in any way and (b) expressly disclaim any liability or responsibility for any loss, damage, costs or expenses incurred in connection with this limitation, including loss, damage, costs and expenses incurred as a result of the negligence of the officers, employees, consultants, contractors, authors, editors or publishers.

Contact ASI: +61 2 8748 0180
enquiries@steel.org.au
visit: www.steel.org.au.

